

Model ARM-60, 90, 120 "Turbo" Portable Oil Filtration System 60, 90, 120 pound capacity



Construction

- Filter pan, motor shroud, and handle are constructed of 302 stainless steel, all other surfaces are NSF approved materials
- Durable 3" casters, 2 swivel, and 2 fixed for easy movement
- 1/3 HP heavy duty "Turbo" pump motor
- 8 gallon per minute, non-shear "Turbo" pump
- 15" x 22" envelope style filter (90 & 120 pound models)
15" x 17" envelope style filter (60 pound model)
- 6 foot flexible, sanitary, high temperature return hose equipped with 2 foot stainless steel wand with non-heat conducting handle
- Filter pan designed to hold 60, 90, 120 pounds of 350F fryer oil



Standard Features:

- 10 foot oil and water proof 115v supply extension cord supplied
- Filter screen assembly and removable suction riser tube
- Hoses assemblies are removable without tools
- 1/3 HP heavy duty "Turbo" pump motor with stainless steel shroud
- 8 foot return hose with stainless wand and **safety shut off** quick connect fitting
- 8 gallon per minute, non-shear Haight highly efficient Turbo pump
- Five extra large 15" x 22", or 15" x 17" **Masterfil™** fabric filter envelopes (five week supply)
- Removable stainless push handle with power cord keeper.

Available Options and Accessories:

- Crumb Basket Stainless Steel Lid 10 pack of **Masterfil™** filters

Other Available Products to Enhance Filtration:

- Fryer Boil Out Digital Oil Tester
 X-Tend Filter Powder Magnesol Filter Powder

ARM-60, 90, 120 "Turbo" Portable Oil Filtration System

60, 90, 120 pound capacity

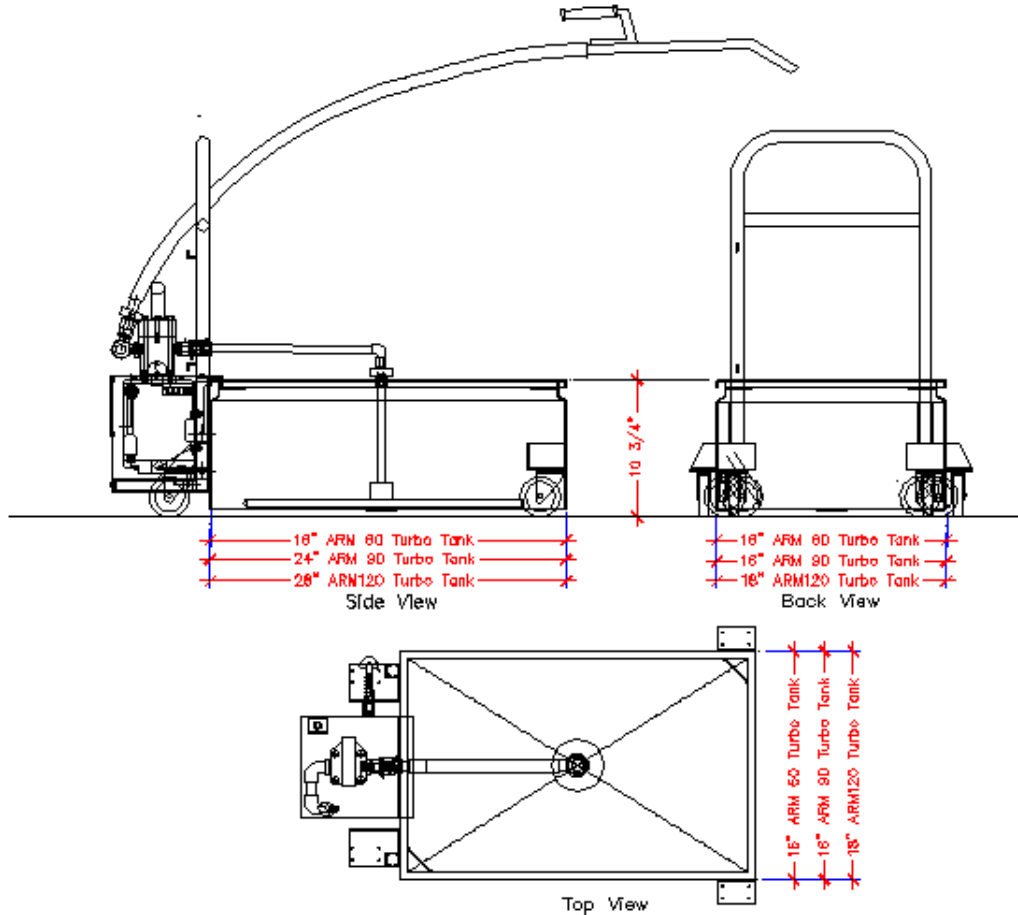

SPECIFICATIONS OF PORTABLE OIL FILTER MACHINES

	MODEL # ARM-60	MODEL # ARM-90	MODEL # ARM-120
NOMINAL FAT CAPACITY	60 Pounds	90 Pounds	120 Pounds
TANK SIZE L x W x H	16" x 16" x 11"	24" x 16" x 11"	28" x 18" x 11"
ELECTRIC POWER	115V / 60HZ / 1 phase		
MOTOR SIZE	1/3 HP with Overload Protection		
PUMP CAPACITY	8 Gallons Per Minute		
SHIPPING WEIGHT*	82 Pounds	88 Pounds	92 Pounds

Motor and Tank Shipped Separately*

Specification: Provide ___ each Oil Solutions Group Model number ARM-____, Portable Filtration System, with 8 gallon per minute Haight Turbo pump, and 1/3 hp, 115v motor. Unit shall pull oil from filter tank through Micro-channel *Masterfil™* Filter media that is capable of filtering down to ½ micron. Entire filter pan, handle, envelope separator, and motor shroud shall be stainless steel construction, all other metal surfaces shall be NSF approved materials.